

# Upper lid D9

In AISI 304 o AISI 316/L stainless steel  
Mat. AISI304/1.4301 lub AISI316L/1.4404



Standard handwheel: nylon handwheel (vlt1207004)

Standard gasket: EPDM gasket in cover

Standard surface finish: polished cover/ frame 2B

Standardowo pokrętko: Plastikowe pokrętko (VLT1207004)

Standardowo uszczelka: EPDM zakładana w pokrywie

Standardowe wykończenie powierzchni: pokrywa polerowana / kołnierz 2B

A	Ø 150	Ø 200	Ø 250	Ø 300	Ø 360	Ø 385	Ø 420	Ø 455	Ø 500	Ø 600
B	2,0	2,5	2,5	2,5	2,5	2,5	2,5	2,5	2,5	2,5
C	45/90	50/100	50/100	50/100	50/100	50/100	50/100	50/100	50/100	50/100
D							130/250	130/250	130/250	130/250
E	1,5	2,0	1,5	1,5	1,5	1,5	1,5	1,5	1,5	2,0
F		Ø16,5	Ø16,5	Ø17	Ø15	Ø16,5	Ø13	Ø15,5	Ø17	Ø17
G	260,0	310,0	360,0	410	470,0	495,0	530,0	565,0	610,0	710,0
P max.	0,02	0,02	0,02	0,02	0,02	0,02	0,02	0,00	0,00	0,00

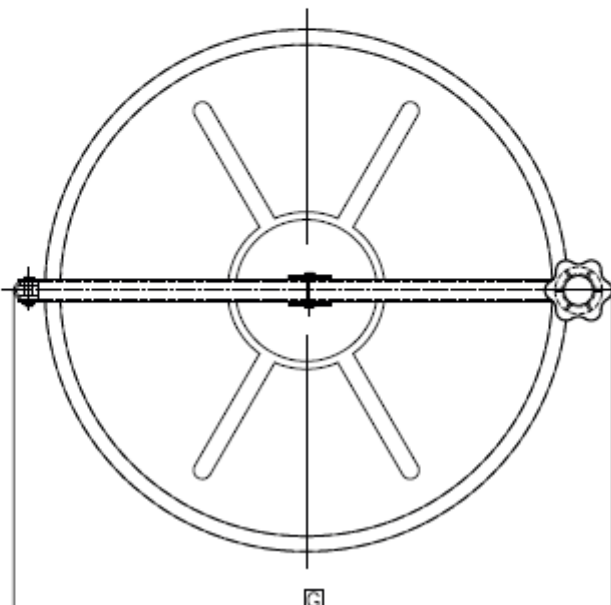
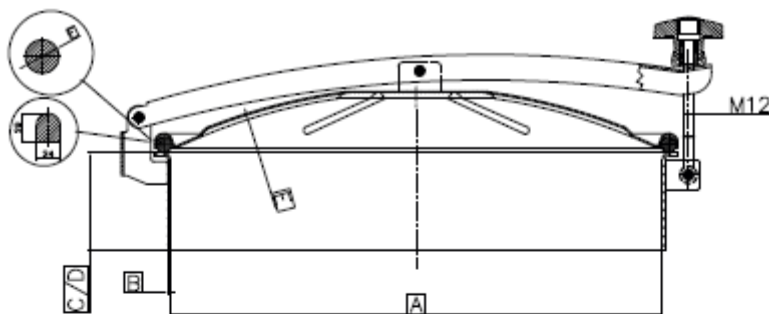

Available gaskets	
TYPE OF MATERIAL	TEMPERATURE
EPDM	-35°/+110°
NITRILE (NBR)	-15°/+110°
SILICON	-35°/+200°
VITON	-20°/+200°